

# KAB//Seating

## 800 Series



KAB 816

KAB AIR 856



ENTER THE COMFORT ZONE

[www.kabseating.com](http://www.kabseating.com)

# KAB // Seating

## 800 Series

**Air and Mechanical suspension seating for the agricultural and construction sectors**

Features	Air 856	816
Air suspension with a 12v integral compressor	●	
Air suspension with a 24v integral compressor	○	
Mechanical suspension		●
175mm vertical suspension stroke	●	●
75mm integral height adjustment	●	●
Driver weight adjustment in kgs	50-120	50-120
Ride indicator	●	●
Suspension cover	●	●
5 position lumbar support	●	●
Fore and aft slide-rail adjustment of 160mm in 10mm steps	○	○
Horizontal isolator with damper includes fore and aft adjustment of 150mm	○	○
Backrest angle adjustment	●	●
Seat belt to ISO 6683, SAE J386 & ISO 3776	○	○
Seat belt widths 50mm (2") & 75mm (3")	○	○
Adjustable armrests (50/70/80/100mm)	○	○
Backrest extension	○	○
Cushion heaters	○	○
Turntable	○	○
Swivel 0-10-20° left or right	○	○
Document pouch	○	○
Seat sensor switch	○	○
Variable up-stop	○	○
Range of fabrics and PVC	○	○
Double dampers	○	○
Adjustable damper (3 positions)	○	○

**Notes**

- Meets ISO 7096
- Meets EEC 78/764 with amendments 83/190 and 88/468 Class I, II and III
- Meets flammability standards FMVSS 302 and ISO 3795 (<250mm/min)

- Standard
- Optional

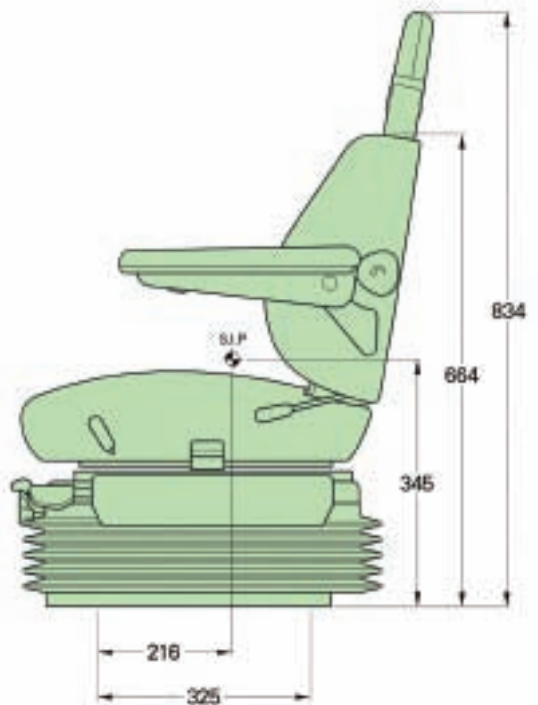
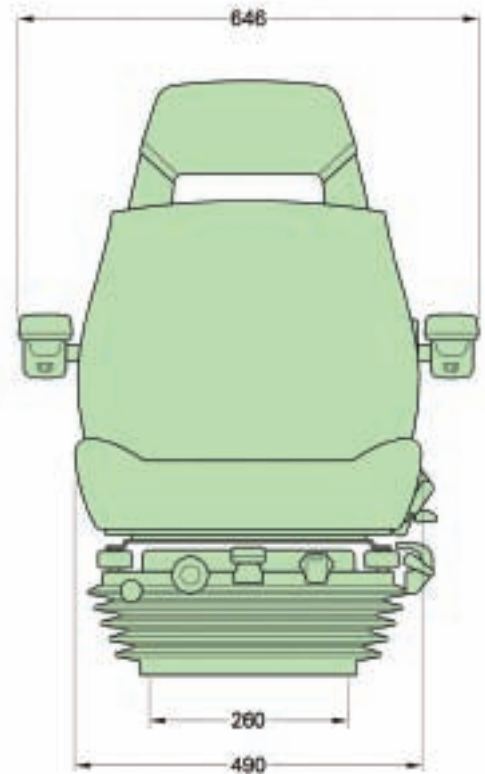

- SIP to ISO 5353.
- Dimensions at mid suspension stroke, middle height adjustment and at mid sliderail adjustment.
- Indicative dimensions
- Air 856 shown

**Distributor**

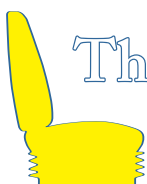

**Thomas Scott (Seating)**

79 Eastmuir Street, Annick Industrial Estate, Glasgow, U.K. G32 OHS

Tel:- +44-(0)141-763-2120 Fax:- +44-(0)141-763-2144

E-Mail:- info@drivers-seats.com Web:- www.drivers-seats.com

**These models are just part of the extensive 800 series range. Other high back, low back and narrower seats are also available.**

**For further details contact your local KAB office.**