

KAB // Seating

700/400 Series

AIR 714

414



ENTER THE COMFORT ZONE

www.kabseating.com

BACK
FRIENDLY

KAB // Seating

700/400 Series

Air and mechanical suspension seating for the Truck, Bus and Construction sectors

Features	714	414
Automatic Air suspension	●	
Mechanical suspension		●
100mm vertical suspension stroke (4")	●	●
75mm vertical suspension stroke (3")	○	○
60mm height and tilt adjustment	●	●
100mm height & tilt adjustment (4")	○	○
Driver weight adjustment 50-120kg (110-265lbs)	automatic	manual
Left/right/front controls	○	○
Suspension cover	●	●
5 position lumbar support	○	○
Fore and aft isolator	○	○
Fore and aft adjustment 160mm (6¼")	●	●
Backrest angle adjustment	●	●
Seat belt 50mm (2") and 75mm (3")	○	○
Suspension lockout	○	○
Adjustable armrests (50/70/80/100mm widths)	○	○
Adjustable headrest	○	○
Cushion heaters 12v or 24v	○	○
Rapid air dump valve	○	
Range of fabrics and PVC	○	○
Vibration performance to ISO7096		○
Manual Air Suspension	○	
Untrimmed versions	○	○
Seat belt to ISO 6683, SAE J386 and ISO 3776 (anchorage strength 15kn)		○

● Standard ○ Optional

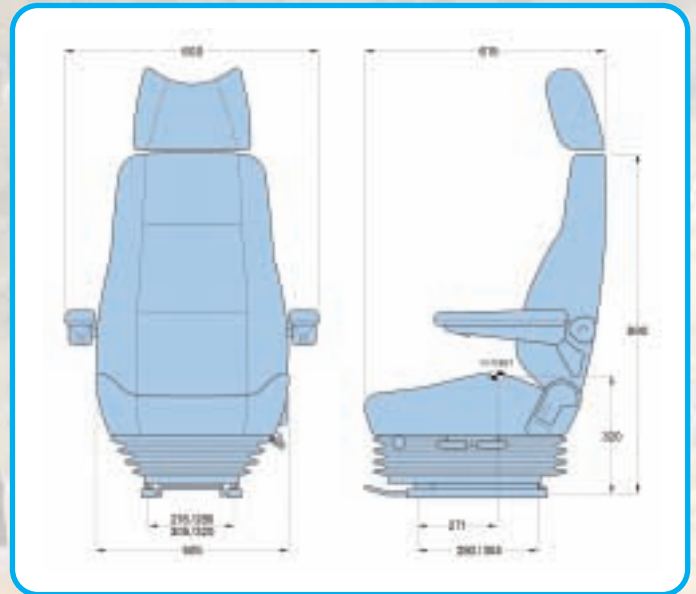

714 shown above with H-Point

- Dimensions at mid suspension stroke, lowest height adjustment and fully back on sliderail adjustment

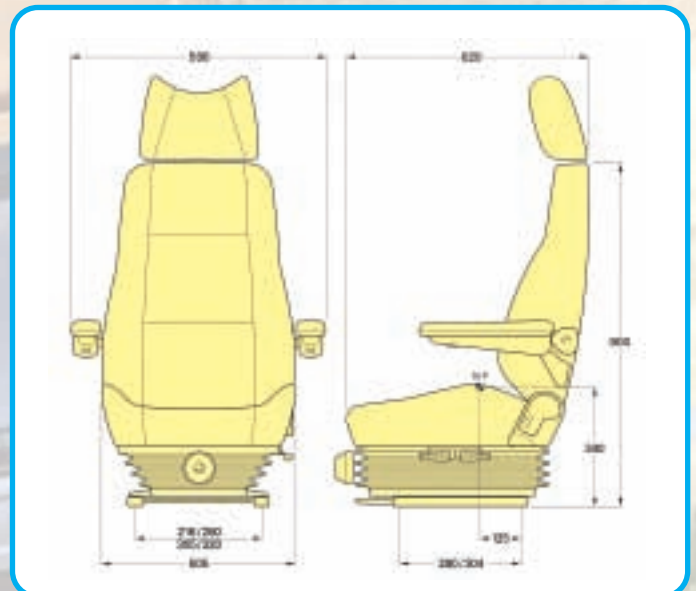

- SIP to ISO 5353
- Dimensions at mid suspension stroke, mid height adjustment and at mid sliderail adjustment
- Indicative dimensions

Distributor



Thomas Scott (Seating)

79 Eastmuir Street, Annick Industrial Estate, Glasgow, U.K. G32 OHS

Tel:- +44-(0)141-763-2120 Fax:- +44-(0)141-763-2144

E-Mail:- info@drivers-seats.com Web:- www.drivers-seats.com

These models are just part of the 700/400 series. Other high back and low back seats are also available.

For further details contact your local KAB office.