

KAB//Seating

500/700 B-Series



**KAB
AIR 714B**

KAB AIR 554B



ENTER THE COMFORT ZONE

www.kabseating.com

KAB//Seating

500/700 B-Series

Air suspension seating for the Truck and Bus sector

Features	554B	714B
Air suspension with manual valve	●	
Automatic air suspension		●
Vertical suspension stroke	125mm	75mm
Height and tilt adjustment	60mm	100mm
Driver weight adjustment in kg	50-150	50-120
Left or right hand controls	○	○
Suspension cover	●	●
Air lumbar support	●	●
Fore and aft adjustment	●	●
	180mm	160mm
Rotary backrest recliner with double locking for extra safety	●	●
3 point seat belt with extra length for large drivers meets M2, M3, N2, N3*	●	●
Heavy Duty Tethers	●	●
Self adjusting sash belt guide	●	●
Adjustable armrests (50/70/80/100mm) widths	○	○
Adjustable headrest	○	○
Cushion heaters	○	○
Range of fabrics and PVC	○	○

● Standard ○ Optional

***Caution. Safety Requirement. Ensure vehicle floor mountings conform to ECE14/ADD 13/REV 1/AMEND 1 or equivalent BEFORE fitting this seat!**

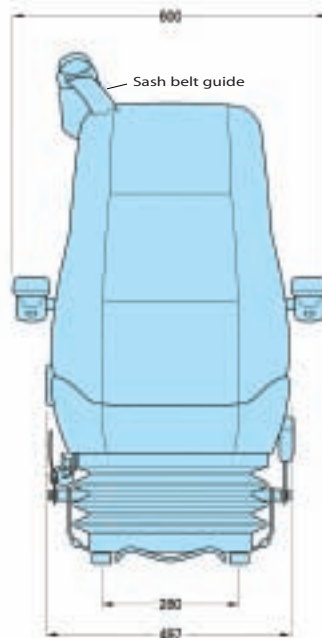

Air 554B

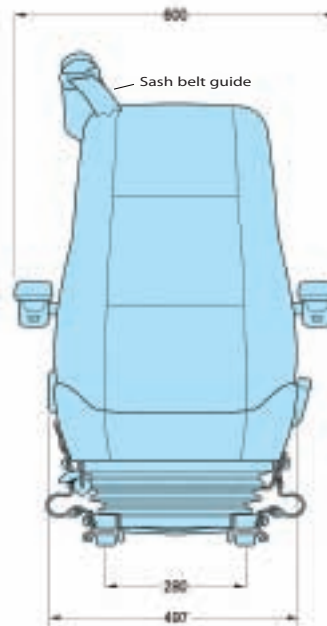
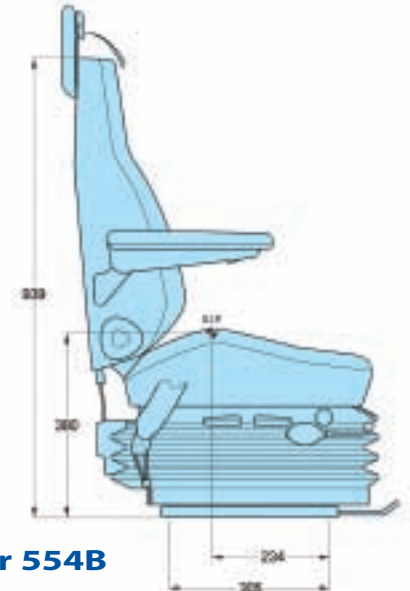

Air 714B

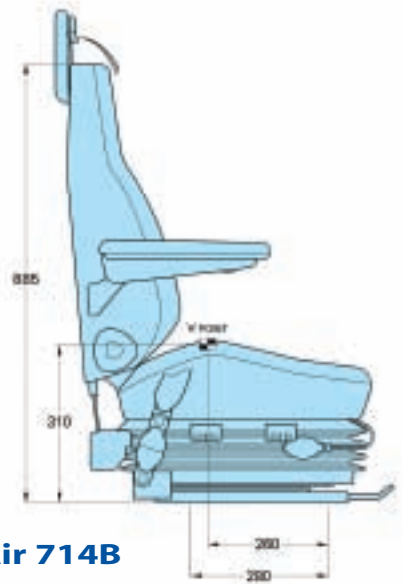

- SIP to ISO 5353
- Dimensions at mid suspension stroke, lowest height adjustment and fully back on sliderail adjustment
- Indicative dimensions

Distributor



Thomas Scott (Seating)

79 Eastmuir Street, Annick Industrial Estate, Glasgow, U.K. G32 OHS

Tel:- +44-(0)141-763-2120 Fax:- +44-(0)141-763-2144

E-Mail:- info@drivers-seats.com Web:- www.drivers-seats.com

KAB B-Series Air seats have enhanced comfort 3 point seat belts to protect the driver. The seat belts move with the driver as the suspension reacts to the normal road surface. This avoids belt chafing as when a conventional B-post mounted belt is used with a suspension seat.