

KAB//Seating

500 Series



**KAB
AIR 555P**
(To take customer pods)

KAB 525P



ENTER THE COMFORT ZONE

www.kabseating.com

KAB // Seating

500 Series

Air and mechanical suspension seating for the construction and marine sectors

Features	Air 555P	525P
Air suspension (Manual Air Valve)	●	
Air suspension with 12v or 24v integral compressors	●	
Mechanical suspension		●
Vertical suspension stroke	● 125mm (5")	● 100mm (4")
60mm height and tilt adjustment	●	●
Driver weight adjustment	● 50-150kgs (110-330lbs)	● 80-150kgs (175-330lbs)
Suspension cover	●	●
Moulded control pods to carry hydraulic electronic control joysticks	●	●
Control pod height adjustment 50mm	●	●
Control pod height adjustment 40mm (relative to joystick)	●	●
Fore and aft adjustment of 160-200mm (relative to control pods)	●	●
Backrest angle adjustment	●	●
Seat belt to ISO 6683, SAE J386 (anchorage strength 15Kn)	●	●
Tether belt version to SAE J386, June 1985 (anchorage strength 22Kn)	○	○
Seat belt widths 50mm (2") & 75mm (3")	○	○
Adjustable armrests (50/70/80/100mm widths)	○	○
5 position lumbar support	○	○
Adjustable headrest	○	○
Cushion heaters	○	○
Adjustable damper	○	○
Double dampers	○	○
Seat sensor switch	○	○
Turntable 0° - 180°	○	○
Front controls	●	●
Range of fabrics and PVC	○	○

● Standard ○ Optional

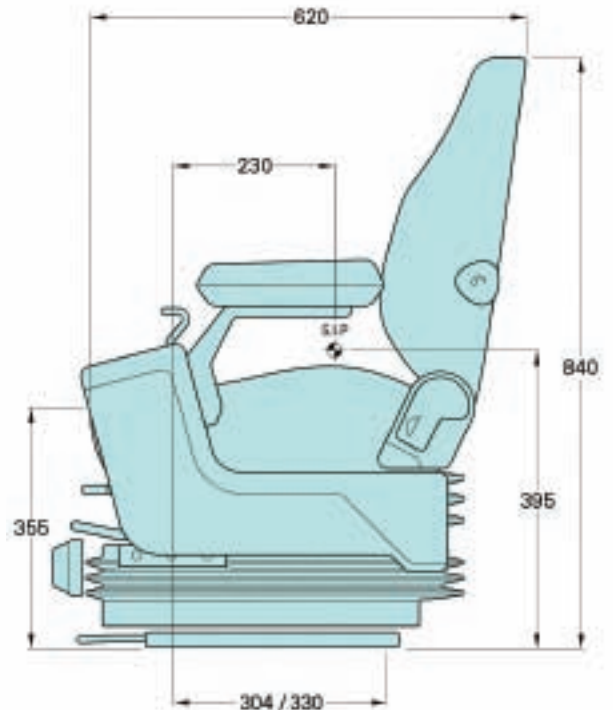
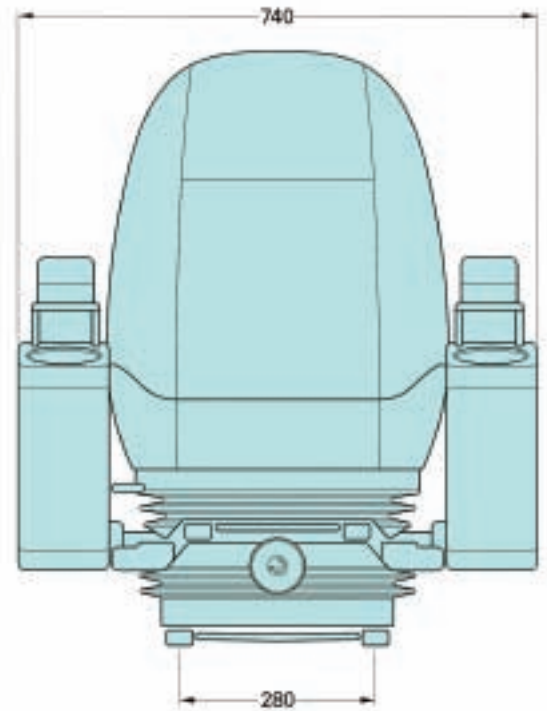

- SIP to ISO 5353.
- Dimensions at mid suspension stroke, middle height adjustment and at mid sliderail adjustment.
- Indicative dimensions
- Air 525P shown

The great value of the KAB pod seats are that the joysticks move with the driver and the suspension of the seat. This creates a better ergonomic working environment and reduces stretching injuries.

These models are just part of the extensive 500 series range. Other high back, low back and narrower seats are also available including the new 55/E-1P and 52/E-1P.

For further details contact your local KAB office.

Distributor



Thomas Scott (Seating)

79 Eastmuir Street, Annick Industrial Estate, Glasgow, U.K. G32 OHS
 Tel:- +44-(0)141-763-2120 Fax:- +44-(0)141-763-2144
 E-Mail:- info@drivers-seats.com Web:- www.drivers-seats.com