

KAB//Seating

500 Series



KAB 515
KAB 525



KAB AIR 555

ENTER THE COMFORT ZONE

www.kabseating.com

KAB // Seating

500 Series

Air and Mechanical suspension seating for the construction and marine sectors

Features	515	525	Air 555
Air suspension (Manual Air Valve)			●
Air suspension with 12v or 24v integral compressors			●
Mechanical suspension	● 2 Springs	● 4 Springs	
100mm vertical suspension stroke	●	●	
125mm vertical suspension stroke			●
60mm height and tilt adjustment	●	●	●
Driver weight adjustment in kgs	50-120	80-150	50-150
Suspension cover	●	●	●
5 position lumbar support	●	●	●
Fore and aft adjustment 200mm 10mm increments	●	●	●
Backrest angle adjustment	●	●	●
Vibration performance to ISO 7096	●	●	●
Seat belt to ISO 6683, SAE J386 and ISO 3776 (anchorage strength 15Kkn)	●	●	●
Tether belt version to SAE J386, June 1981 (anchorage strength 22Kkn)	○	○	○
Seat belt widths 50mm (2") & 75mm (3")	○	○	○
Adjustable armrests (50/70/80/100mm)	○	○	○
Adjustable headrest	○	○	○
Cushion heaters	○	○	○
Adjustable damper (3 positions)	○	○	○
Double dampers	○	○	○
Seat sensor switch	○	○	○
Turntable 0°-180°	○	○	○
Front or side controls available	○	○	○
Range of fabrics and PVC	○	○	○

● Standard ○ Optional

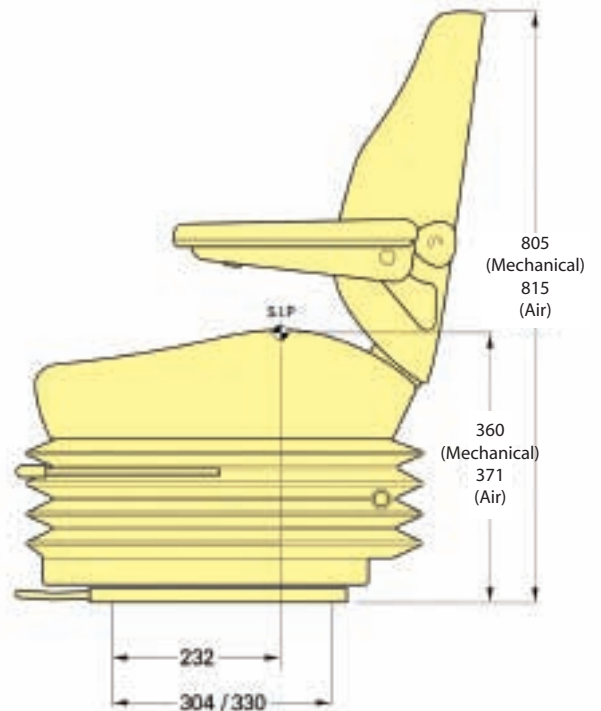
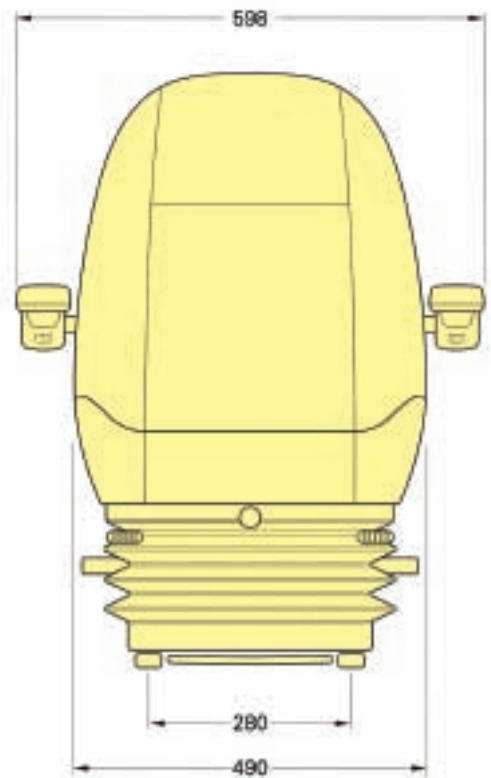

- SIP to ISO 5353.
- Dimensions at mid suspension stroke, middle height adjustment and at mid sliderail adjustment.
- Indicative dimensions
- Air 555 shown

Distributor



Thomas Scott (Seating)

79 Eastmuir Street, Annick Industrial Estate, Glasgow, U.K. G32 OHS

Tel:- +44-(0)141-763-2120 Fax:- +44-(0)141-763-2144

E-Mail:- info@drivers-seats.com Web:- www.drivers-seats.com

These models are just part of the extensive 500 series range. Other high back, low back and narrower seats are also available.

For further details contact your local KAB office.