

# KAB//Seating

## 500 Series



**KAB 514**  
**KAB 524**

**KAB AIR 554**



ENTER THE COMFORT ZONE

[www.kabseating.com](http://www.kabseating.com)



# KAB // Seating

## 500 Series

**Air and mechanical suspension seating for the construction, truck and marine sectors**

Features	Air 554	514	524
Air suspension (Manual Air Valve)	●		
Air suspension with 12v or 24v integral compressors	●		
Mechanical suspension		● 2 Springs	● 4 Springs
100mm vertical suspension stroke (4")		●	●
125mm vertical suspension stroke (5")	●		
60mm height and tilt adjustment (2 1/2")	●	●	●
Driver weight adjustment	50-150 (110-330lbs)	50-120 (110-265lbs)	80-150 (175-330lbs)
Suspension cover	●	●	●
5 position lumbar support	●	●	●
Fore and aft adjustment of 200mm (8") 10mm increments	●	●	●
Backrest angle adjustment	●	●	●
Vibration performance to ISO 7096	●	●	●
Seat belt to ISO 6683, SAE J386 & ISO 3776 (anchorage strength 15Kn)	●	●	●
Tether belt version to SAE J386, June 1985 (anchorage strength 22Kn)	○	○	○
Seat belt widths 50mm (2") & 75mm (3")	○	○	○
Adjustable armrests (50/70/80/100mm widths)	○	○	○
Adjustable headrest	○	○	○
Cushion heaters	○	○	○
Adjustable damper	○	○	○
Double dampers	○	○	○
Seat sensor switch	○	○	○
Turntable 0° - 180°	○	○	○
Front or side controls available	○	○	○
Range of fabrics and PVC	○	○	○

● Standard ○ Optional

**The KAB Air554 with tethers meets FMVSS 207/210 tests applicable for heavy trucks in North America. It also complies with M2, M3 and N2, N3 for Europe.**

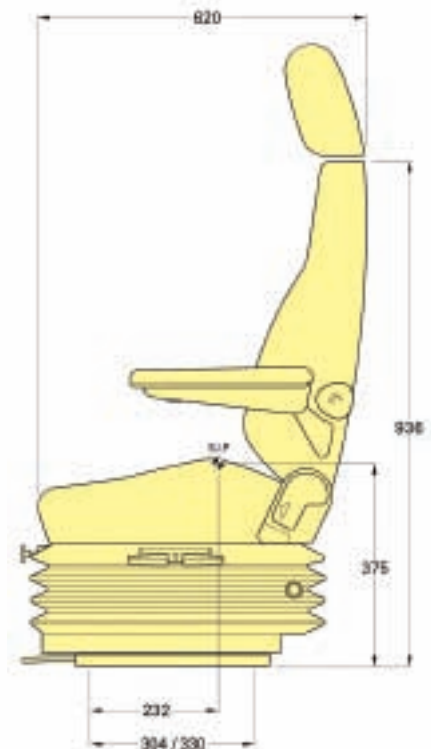
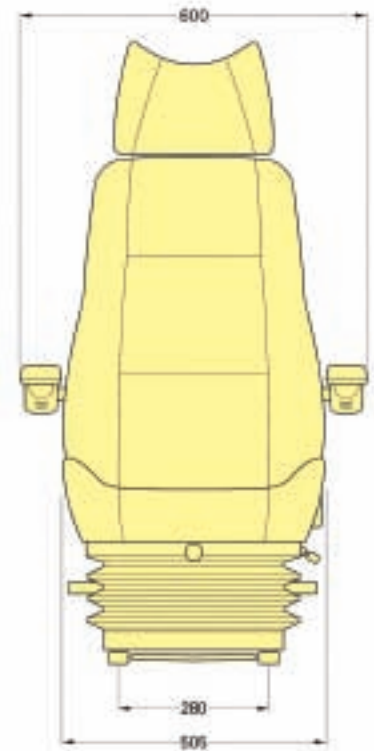

- SIP to ISO 5353.
- Dimensions at mid suspension stroke, middle height adjustment and at mid sliderail adjustment.
- Indicative dimensions
- Air 554 shown

Distributor



Thomas Scott (Seating)

79 Eastmuir Street, Annick Industrial Estate, Glasgow, U.K. G32 OHS

Tel:- +44-(0)141-763-2120 Fax:- +44-(0)141-763-2144

E-Mail:- info@drivers-seats.com Web:- www.drivers-seats.com

**These models are just part of the extensive 500 series range. Other high back, low back and narrower seats are also available.**

**For further details contact your local KAB office.**