

# KAB//Seating

## 300 Series



**KAB 301K  
MARINE**

**KAB 301K**



ENTER THE COMFORT ZONE

[www.kabseating.com](http://www.kabseating.com)

# KAB // Seating

## 300 Series

**Mechanical suspension seating for the construction and marine sectors**

Features	301K	300K
Mechanical suspension with double acting hydraulic damper	●	●
100mm vertical suspension stroke (4")	●	●
Seat height and tilt adjustment 60mm (2½")	●	
Driver weight adjustment 50-120kgs (110-265lbs)	●	●
Suspension cover	●	●
Backrest angle adjustment 12°	●	●
Fore and aft adjustment 160mm (6¼")	●	●
Seat belt widths 50mm (2") & 75mm (3")	○	○
Adjustable armrests (50/70/80/100mm)	○	○
Adjustable headrest	○	○
Cushion heaters 12v or 24v	○	○
Turntable/Mounting pedestal 0°-180°	○	○
Double damper version	● 301KS	
Range of fabrics and PVC	○	○
Flat PVC drainage cushions	○	
Vibration performance to ISO 7096	●	●
Seat belt to ISO 6683, SAE J386 and ISO 3776 (anchorage strength 15kn)	●	●
Tether belt version SAE J386 June 1985 (anchorage strength 22kn)	○	○

● Standard ○ Optional

**The 300/301 series has a great reputation and has been used for many years in harsh environments. Its stable torsion bar suspension system provides maximum operator protection from harmful vibrations**

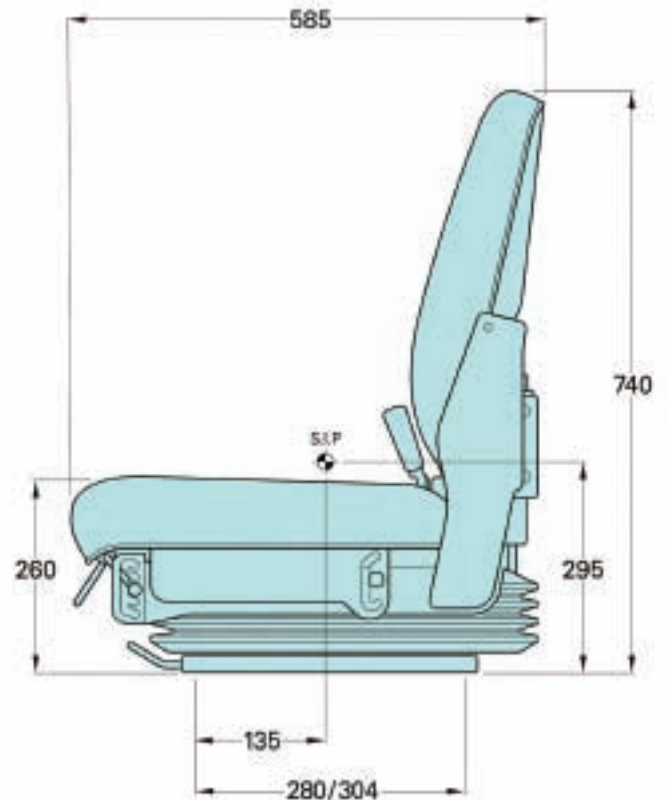
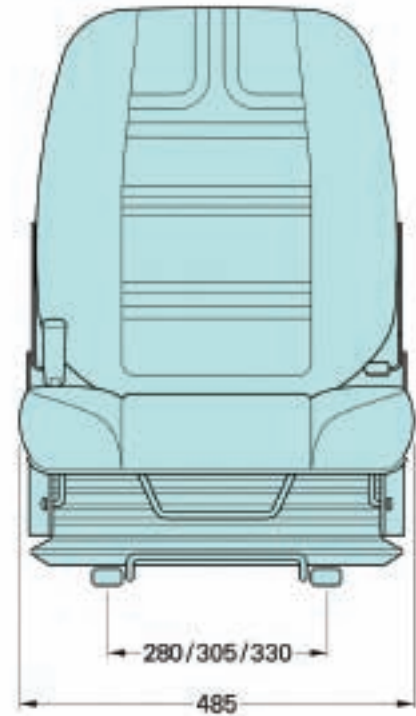

- SIP to ISO 5353.
- Dimensions at mid suspension stroke, middle height adjustment and at mid sliderail adjustment.
- Indicative dimensions
- 301K shown

**These models are just part of the extensive 300 series range. Low back and static seats are also available.**

**For further details contact your local KAB office.**

Distributor



Thomas Scott (Seating)

79 Eastmuir Street, Annick Industrial Estate, Glasgow, U.K. G32 OHS

Tel:- +44-(0)141-763-2120 Fax:- +44-(0)141-763-2144

E-Mail:- info@drivers-seats.com Web:- www.drivers-seats.com