

# KAB//Seating

## 200 Series

KAB AIR 254

KAB 214



KAB AIR 254

ENTER THE COMFORT ZONE

[www.kabseating.com](http://www.kabseating.com)

# KAB // Seating

## 200 Series

Low profile Air and Mechanical seating for the forklift and ride-on mower sectors

Features	Air 254	214
Manual air valve with weight adjustment (50-120kgs)	●	
Mechanical weight adjustment in 5 steps (50-120kgs)		●
Seat tilt adjustment	●	○
Backrest angle adjustment 10° in 3 increments	●	○
Fore and aft adjustment in 15mm increments	210mm	195mm
50mm vertical suspension stroke	●	●
12 or 24 volt integral compressor	●	
Seat belt	○	○
Hip guards	○	○
Armrests (50/70mm wide)	○	○
Heater elements	○	○
Seat sensor switches	○	○
Vehicle immobiliser switch	○	○
Seat belt (anchorage to ISO 3776)	●	●
Water resistant and draining facility (PVC only)	○	○
Range of fabric or PVC trims	○	○

- Standard
- Optional

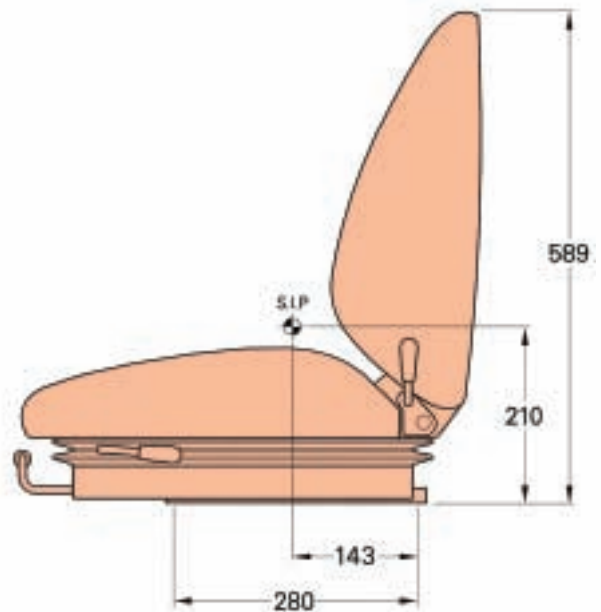
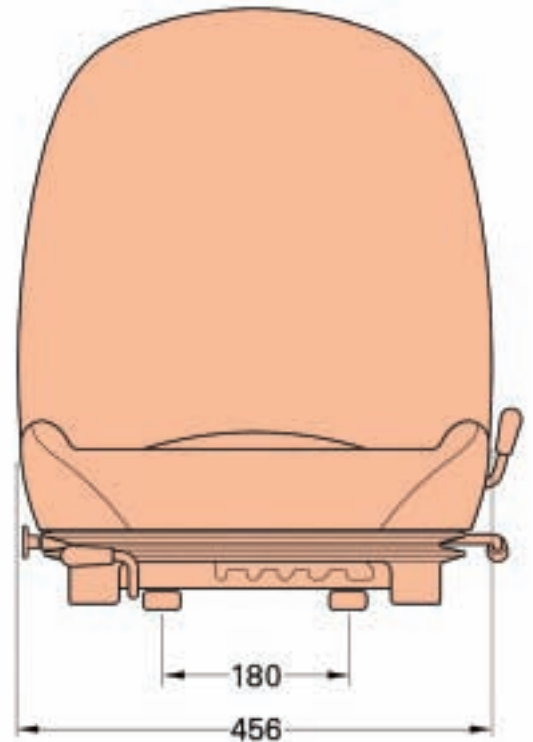

- SIP to ISO 5353.
- Dimensions at mid suspension stroke, middle height adjustment and at mid sliderail adjustment.
- Indicative dimensions
- Air 254 shown

**The Air 25 and 21 mechanical are modular suspensions which can also be used with a wide variety of high back/low back seat uppers and pans.**

**For further details contact your local KAB office.**

### Distributor



## Thomas Scott (Seating)

79 Eastmuir Street, Annick Industrial Estate, Glasgow, U.K. G32 OHS  
 Tel:- +44-(0)141-763-2120 Fax:- +44-(0)141-763-2144  
 E-Mail:- info@drivers-seats.com Web:- www.drivers-seats.com