

# KAB//Seating

## 100 Series



KAB 116

KAB AIR156



ENTER THE COMFORT ZONE

[www.kabseating.com](http://www.kabseating.com)

# KAB // Seating

## 100 Series

**Air and Mechanical seating for the agricultural and construction sectors**

Features	Air 156	116
Air suspension with a 12v integral compressor	●	
Air suspension with a 24v integral compressor	○	
Mechanical suspension		●
150mm vertical suspension stroke	●	●
70mm integral height adjustment	0-30 or 70	70
Driver weight adjustment in kgs	50-120	50-120
Ride indicator	●	●
Suspension cover	●	●
5 position lumbar support	●	●
Fore and aft adjustment 160mm	●	●
Backrest angle adjustment	●	●
Seat belt widths 50mm (2") & 75mm (3")	○	○
Adjustable armrests (50/70/80/100mm)	○	○
Backrest extension	○	○
Cushion heaters	○	○
Turntable	○	○
Swivel 0-10°-20° left or right	○	○
Document pouch	○	○
Seat sensor switch	○	○
Variable up-stop	○	○
Range of fabrics and PVC	○	○

**Notes**

- Meets ISO 7096
- Meets EEC 78/764 with amendments 83/190 and 88/468 Class I, II and III
- Meets flammability standards FMVSS 302 and ISO 3795 (<250mm/min)
- Seat belt anchorages to ISO 3776, ISO 6683 and SAE J386

- Standard
- Optional

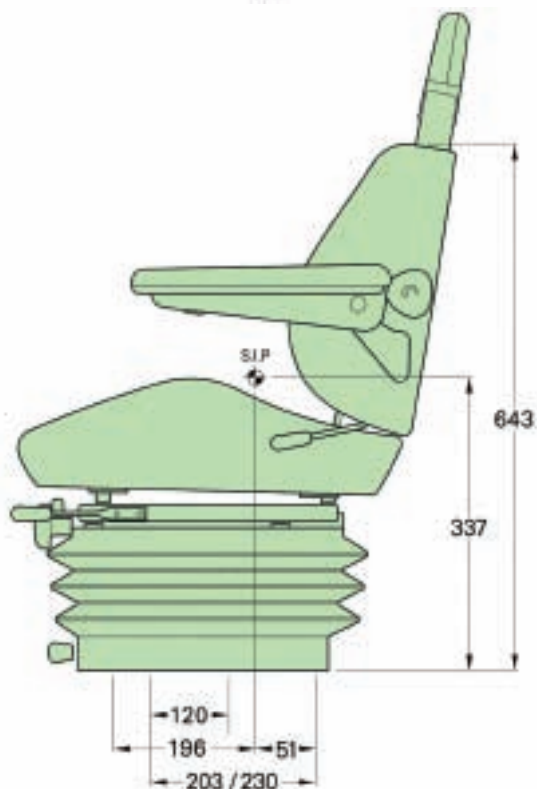
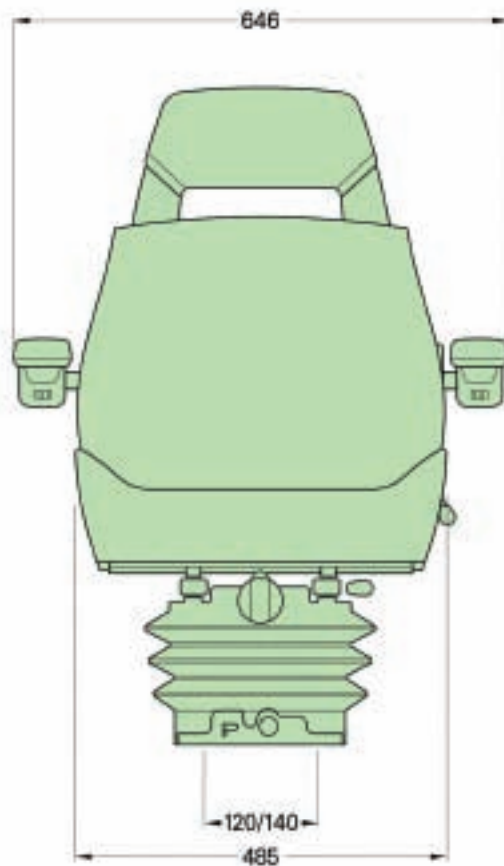

- SIP to ISO 5353.
- Dimensions at mid suspension stroke, middle height adjustment and at mid sliderail adjustment.
- Indicative dimensions
- 116 shown

**The Air 15 and 11 mechanical are modular suspensions which can also be used with a wide variety of seats and pans.**

**For further details contact your local KAB office.**

**Distributor**

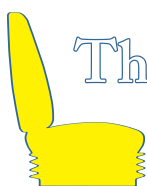

**Thomas Scott (Seating)**

79 Eastmuir Street, Annick Industrial Estate, Glasgow, U.K. G32 OHS

Tel:- +44-(0)141-763-2120 Fax:- +44-(0)141-763-2144

E-Mail:- info@drivers-seats.com Web:- www.drivers-seats.com